

Microminiature Slide Switches for SMT

Specifications:

Contact rating:	12 V DC, 200 mA
Contact resistance:	< 70 mΩ
Insulation resistance:	> 100 MΩ at 500 V DC
Dielectric strength:	500 V, 50 Hz for the duration of 1 minute
Operating temperature:	-40 °C to +85 °C
Storage temperature:	-40 °C to +85 °C
Mechanical life:	minimum 5000 operations
Contacts:	phosphor bronze, silver-plated
Terminals:	brass, silver-plated
Contact timing:	non-shorting
Slide colour:	black

Models:	Switching functions
MMS 124	on on

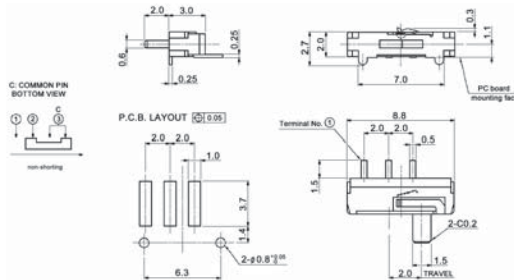

MMS 134	on on on
---------	----------

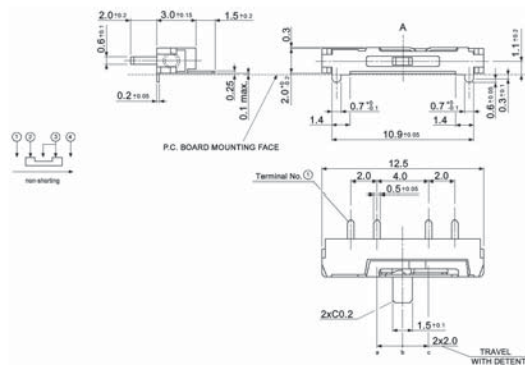

MMS 224	on on
---------	-------

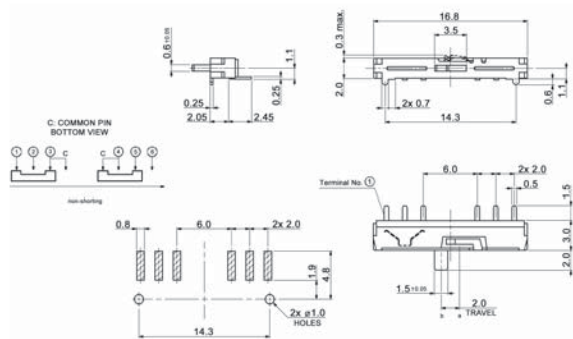

Soldering conditions: reflow-soldering: 40 sec, 220° C
 peak temperature: 5-6 sec, 260° C

Packing: cardboard boxes, on tapes on request

