

P.C.B. LAND DIMENSIONS

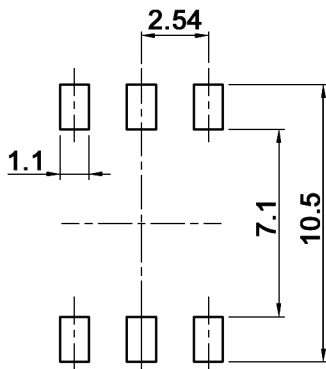

Y Manufacturing year

9	2019
0	2020
1	2021
2	2022

M Manufacturing month

1	January
...	...
9	September
0	October
N	November
D	December

		Real coded				
		C	1	2	4	8
10 P o s i t i o n s	0	●				
	1	●	●			
	2	●		●		
	3	●	●	●		
	4	●			●	
	5	●	●			
	6	●		●	●	
	7	●	●	●	●	
	8	●				●
	9	●	●			●

Compliance: RohS III (2015/863/EU)

Tolerances:	up to 10: ±0.2 mm	Date	Name
	above 10-50: ±0.3 mm	10/22	dr
Diameter dimension	10/24	dr	knitter-switch
Material	02/23	dr	
Modifications	Date	Name	

SMR 14010 (T)

30 49 06

Page

1/3

Specifications:

Contact rating: non-switching: 100 mA, 50 V DC
switching: 100 mA, 5 V DC
min.: 1 μ A, 20 mV AC/DC

Contact resistance: 200 mOhm max. (1 kHz, 20 mA)

Insulation resistance: 1000 MOhm min. at 100 V DC for 1 minute

Dielectric strength: 250 V AC (50/60 Hz, 2 mA) for 1 minute

Operating temperature: -40°C to +85°C

Storage temperature: -40°C to +85°C

Mechanical life: 20 000 cycles

Electrical life: 20 000 cycles

Rotational torque: 24.5 mN.m max.

Material: Terminal: C5191, gold plated
Case: LCP, dark grey
Cover: SUS, washing
Contact plate: BeCu, gold plated
Spring plate: SUS, washing
Rotor: PPA, ivory
Gasket: silicone rubber, black

Soldering conditions:

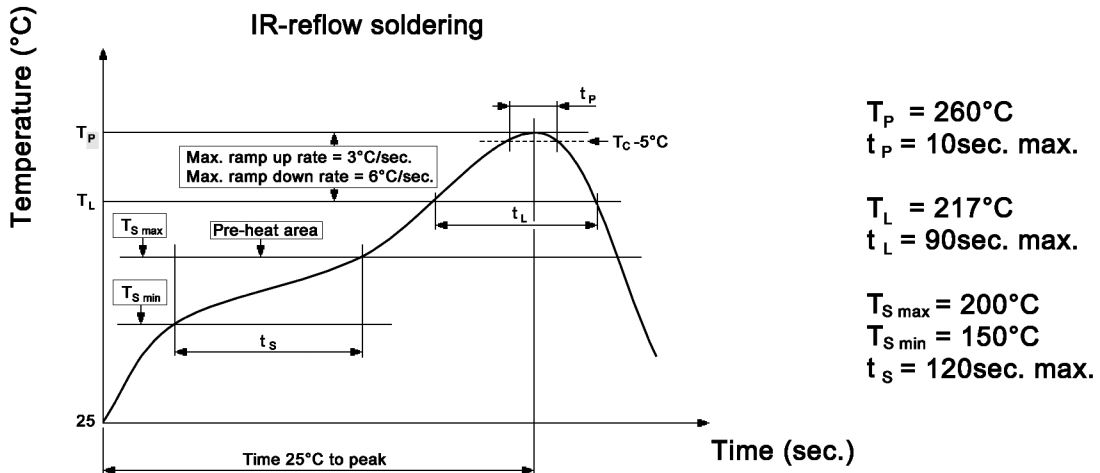

Compliance: RohS III (2015/863/EU)

Tolerances: up to 10: ± 0.2 mm above 10-50: ± 0.3 mm		Date	Name	<h1>SMR 14010 (T)</h1>
		10/22	dr	
Diameter dimension	10/24	dr	<h2>knitter-switch</h2>	<h2>30 49 06</h2>
Material	02/23	dr		
Modifications	Date	Name		2/3

Packaging:

REEL:

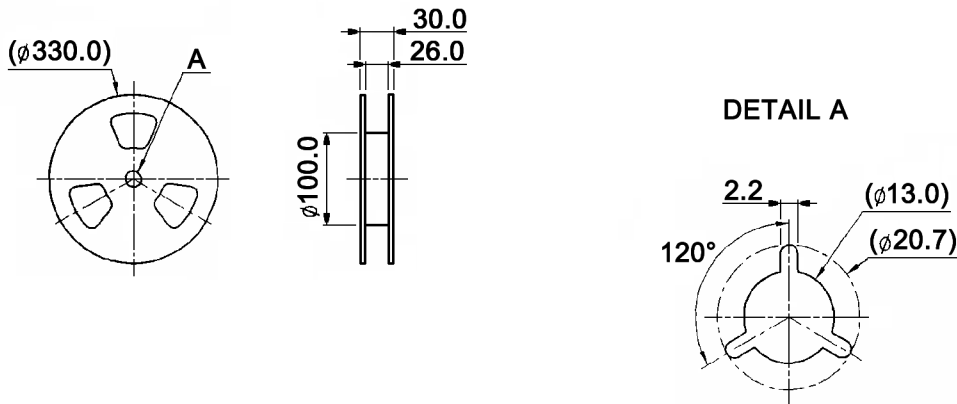

CARRIER TAPE

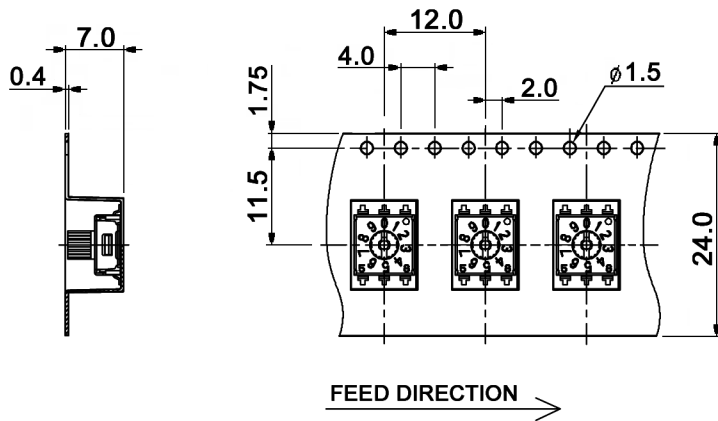

Ordering code	Packaging unit
SMR 14010	65 pcs. / tube
SMR 14010 T	500 pcs. / reel

TUBE:

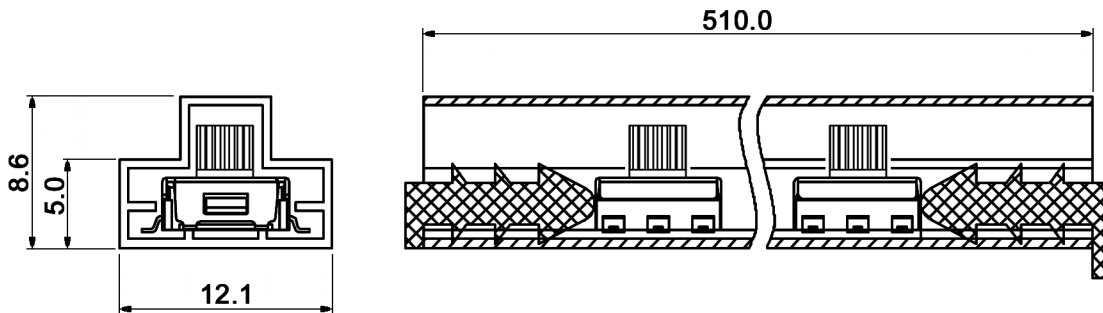

Compliance: RohS III (2015/863/EU)

Tolerances:	up to 10: ±0.2 mm	above 10-50: ±0.3 mm	Date	Name
			10/22	dr
Diameter dimension	10/24	dr	knitter-switch	
Material	02/23	dr		
Modifications	Date	Name		

SMR 14010 (T)

30 49 06

Page

3/3